



Vertex Water Features

Lake Aeration Systems & Floating Fountains

With
Vertex
MicronBubble™
Technology

B O T T O M A E R A T I O N



AIR 1XL™

The Vertex Air 1XL™ is a super-efficient, affordable and safe system for circulating up to 8,190 GPM. In a typical pond with 8 foot depths, an Air 1XL™ can aerate approximately 2 acres depending on dissolved oxygen demand and other factors. A 1/3 hp piston compressor, housed in our rustproof outdoor cabinet, feeds a bottom mounted AirStationXL™ Diffuser utilizing Vertex's MicronBubble™ technology. The majority of bubbles are only 500 to 1000 microns in diameter. As bubble size decreases, oxygen transfer rates increase dramatically. The rising force of millions of bubbles circulates the entire water column, entraining bottom water up to the surface allowing vital oxygen to be absorbed. Oxygen levels are increased and kept constant throughout the entire lake, preventing drastic O₂ swings that can lead to fish-kills. With no electricity in the water, Vertex's aeration systems are safe for any type of water recreation. Our self-cleaning AirStationXL™ Diffuser allows for years of high performance, reliability, low maintenance and are covered under our **five-year warranty**.

FEATURES

AIRSTATIONXL™

- ◆ Four 9" flexible membrane discs with MicronBubble™ technology
- ◆ Self-cleaning, low maintenance, & five-year warranty
- ◆ Rugged EPDM construction
- ◆ One vacuum formed & sonic welded HDPE base unit
- ◆ Hollow design for sand ballast
- ◆ Lipped edge prevents sinking into soft bottom sediments

BROOKWOOD™ COMPRESSOR

- ◆ U.L. listed
- ◆ 1/3 hp for exceptionally low monthly electrical costs
- ◆ Thermal overload protection
- ◆ 115 volt operation
- ◆ One-year warranty

QUIETAIR™ CABINET

- ◆ "Class A" GFCI protection on all circuits
- ◆ Powder coated for durable, attractive finish
- ◆ Heavy duty cooling fan rated at 100 CFM
- ◆ Rustproof aluminum construction
- ◆ Easy plug-in connection to waterside electrical service
- ◆ Equipped with barrel lock for increased security

BOTTOMLINE™ TUBING

- ◆ Self-weighted for easy installation
- ◆ Heavy duty wall thickness (0.24") for durability
- ◆ Available in 100' increments
- ◆ Remains flexible in cold temperatures

BENEFITS TO THE LAKE

- ◆ Air 1XL™ systems circulate the entire water column — up to 8,190 gallons per minute depending on diffuser depth
- ◆ Increased dissolved oxygen
- ◆ Stops oxygen related fish kills by raising entire water column oxygen levels
- ◆ Reduces nutrient levels and associated algae growth
- ◆ Ends thermal stratification
- ◆ Improves fisheries by expanding oxygenated habitat
- ◆ Reduces aquatic midge and mosquito insect hatches
- ◆ Eliminates foul odors from undesirable dissolved gases
- ◆ SAFE — no electricity in the water and full GFCI protection on all circuits

SPECIFICATIONS: AIR 1XL™ LAKE AERATION SYSTEM

BROOKWOOD™ COMPRESSOR

1/3hp, 115v, 1 phase. Piston type built for continuous operation and equipped with thermal overload protection. Unit shall be oil-free and require no scheduled maintenance other than periodic cleaning of included air filter. Compressor produces 1.8 CFM @ 20PSI. 3.7 running amps @ 115 volt.

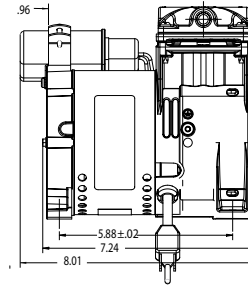

QUIETAIR™ CABINET

Enclosure shall be constructed of aluminum with gray electrostatically-bonded powder coating to provide lifetime warranty against rust. Enclosure shall be equipped with stamped ventilation or grill to provide forced air circulation and an integral cooling fan with thermal protection, producing 106 CFM to guard against excessive compressor operating temperatures. ENCLOSURE COMES EQUIPPED WITH CLASS A GFCI PROTECTION ON BOTH THE COMPRESSOR AND FAN CIRCUITS.

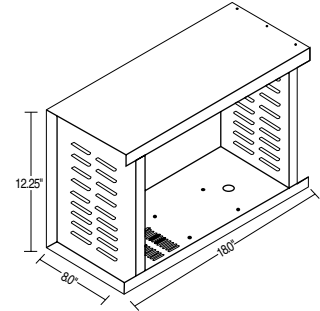

AIRSTATIONXL™ ASSEMBLY

Diffuser station shall consist of four self-cleaning, 9" diameter, flexible membrane diffusers of EPDM compound with 100% rebound memory, each producing millions of fine 500 to 3000 micron bubbles – the majority 500 to 1000 microns. Each diffuser station shall be equipped with vacuum-formed HDPE base, sonic spot-welded to provide unit integrity. Base unit (17.25"L x 13.25"W x 3.35"D) shall be of hollow chamber design for the addition of inert pea gravel ballast and have lipped design to prevent settling into soft bottom sediments.

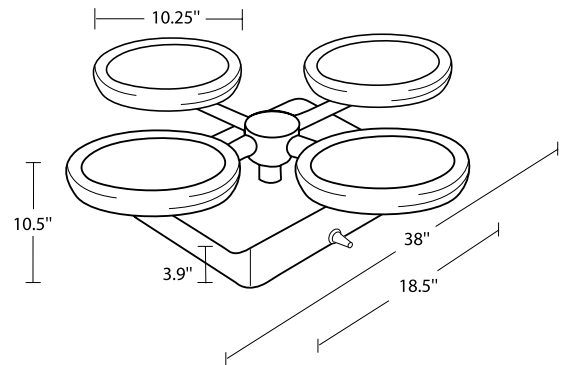

BOTTOMLINE™ SUPPLY TUBING

Self-weighted, direct burial submersible tubing for connection from compressor to diffuser stations. Tubing shall be of flexible PVC composite construction for use with standard PVC solvent weld cement and 0.5" insert fittings. Tubing shall have 0.55" I.D. and 0.24" wall thickness for long term durability and protection against punctures. Remains flexible in cold temperatures.

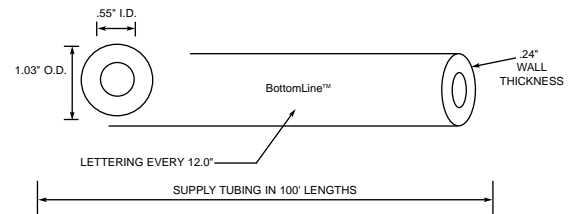

(800) 432-4302 / Fax (954) 977-7877
www.vertexwaterfeatures.com / e-mail: info@vertexwaterfeatures.com

Install all electrical equipment in accordance with Article 680 of the National Electrical Code and all local codes. Vertex Water Features reserves the right to improve and change our designs and/or specifications of our aerators without notice or obligation.
© 2004 Vertex Water Features